



HGM9510

HGM9520 controller is designed for manual/auto parallel systems generators. The controller allows automatic start/stop, data measurement, alarm protection as well as remote control, remote measurement and remote communication. It has LCD display, selectable Chinese, English and other languages interface, and it is reliable and easy to use.

Product Code : 6010034

Power Supply : DC(8-35)V

Case Dimensions : 266*182*45(mm)

Panel Cutout : 214*160(mm)

Operating Temp. : (-25~+70)°C

Weight : 0.95 kg

COMPELTE DESCRIPTION

HGM9520 controller is designed for manual/auto parallel systems generators. The controller allows automatic start/stop, data measurement, alarm protection as well as remote control, remote measurement and remote communication. It has LCD display, selectable Chinese, English and other languages interface, and it is reliable and easy to use.

HGM9520 controller integrates GOV (Engine Speed Governor) and AVR (Automatic Voltage Regulator) control functions. Multiple working modes can be selected, such as genset fixed active power, reactive power/power factor output, mains peak lopping and uninterruptedly restore to mains supply.

HGM9520 controller can accurately monitor multiple running states of the gen-set. When gen-set abnormal condition occurs, it splits bus and shuts down the gen-set; simultaneously the fault condition appears on LCD. HGM9520 controller has SAE J1939 interface that can communicate with a number of ECU (ENGINE CONTROL UNIT) which equip with J1939.

HGM9520 controller adopt 32 bits micro-processor technology with precision parameters measuring, fixed value adjustment, time setting and set value adjusting and etc..Majority parameters can be configured from front panel, and all parameters can be configured by USB interface (or RS485) to adjust via PC. It can be widely used in all types of automatic gen-set control system with compact structure, advanced circuits, simple connections and high reliability.

PERFORMANCE AND CHARACTERISTICS

1. With ARM-based 32-bit SCM, high integration of hardware and more reliable;
2. 480x272 LCD with backlight, multilingual interface (including English, Chinese or other languages) which can be chosen at the site, making commissioning convenient for factory personnel;
3. Improved LCD wear-resistance and scratch resistance due to hard screen acrylic;
4. Silicon rubber panel and pushbuttons for better operation in high/low temperature environment;
5. RS485 communication port enables remote control, remote measuring, remote communication via ModBus protocol.
6. Equipped with CANBUS port and can communicate with J1939 genset. Not only can you monitoring frequently-used data (such as water temperature, oil pressure, speed, fuel consumption and so on) of ECU machine, but also control start, stop , raising speed and speed droop via CANBUS port.
7. Suitable for 3-phase 4-wire, 3-phase 3-wire, single phase 2-wire, and 2-phase 3-wire systems with voltage 120/240V and frequency 50/60Hz;
8. Collects and shows 3-phase voltage, current, power parameter and frequency of mains/generator.
9. Perfect mains split protection: over/under frequency, over/under voltage, ROCOF and vector shift;
10. For generator, controller has over and under voltage, over and under frequency, loss of phase, phase sequence wrong, over and reverse power, over current protection functions;
11. Synchronization parameters : Voltage Difference between generator and mains , Frequency Difference between generator and mains , Phase Difference between generator and mains ;

12. Multiple operation modes in auto state: AMF (Automatic Mains Failure), Island Mode, Fixed Power, Peak Lopping Mode and Load Takeover Mode;
13. Ramp on and ramp off function;
14. 3 fixed sensors (temperature, oil pressure and liquid level);
15. 2 configurable sensors can be set as temperature sensor, oil pressure sensor or fuel level sensor;
16. More kinds of curves of temperature, oil pressure, fuel level can be used directly and users can define the sensor curves by themselves ;
17. Precision measure and display parameters about Engine,
18. Control and protection: automatic start/stop of the diesel genset, ATS(Auto Transfer Switch) control with perfect fault indication and protection function;
19. All output ports are relay output;
20. Parameter setting: parameters can be modified and stored in internal EEPROM memory and cannot be lost even in case of power outage; most of them can be adjusted using front panel of the controller and all of them can be modified using PC via USB or RS485 ports;
21. Multiple crank disconnect conditions (speed sensor, oil pressure, generator frequency) are optional;
22. Widely power supply range DC(8~35)V, suitable to different starting battery voltage environment;
23. Event log, real-time clock, scheduled start & stop generator (can be set as start genset once a day/week/month whether with load or not);
24. Accumulative total run time and total electric energy of A and B. Users can reset it as 0 and re-accumulative the value which make convenience to users to count the total value as their wish.
25. Can control engine heater, cooler and fuel pump.
26. With maintenance function. Actions (warning, trip and stop, shutdown) can be set when maintenance time out;
27. All parameters used digital adjustment, instead of conventional analog modulation with normal potentiometer, more reliability and stability;
28. IP55 waterproofness level can be achieved with the help of rubber-ring gasket between shell and control panel.
29. Metal fixing clips enable perfect in high temperature environment ;
30. Modular design, anti-flaming ABS plastic shell, pluggable terminal, built-in mounting , compact structure with easy installation ;

PARAMETER LIST

Function Item	Parameter
Display	4.3 inches TFT-LCD (480*272)
Operation Panel	Silicon Rubber
Language	Chinese & English & Others

Function Item	Parameter
Digital Input	8
Relay Output	8
Analogue Input	5
AMF	●
AC System	1P2W/2P3W/3P3W/3P4W
Alternator Voltage	(15~360)V(ph-N)
Alternator Frequency	50/60Hz
kW/Amp Detecting & Display	●
Monitor Interface	RS485
Programmable Interface	USB/RS485
CANBUS(1939)	●
RTC & Event Log	●
Scheduled Start Genset	●
Maintenance	●
ULP	●
DC Supply	DC(8-35)V

Function Item

Parameter

Case Dimensions(mm)

266*182*45

Panel Cutout(mm)

214*160

Operating Temp.

(-25~+70)°C

Function Item

Parameter

Display

4.3 inches TFT-LCD (480*272)

HGM9520 Typical Application

HGM9520 Typical Application Diagram

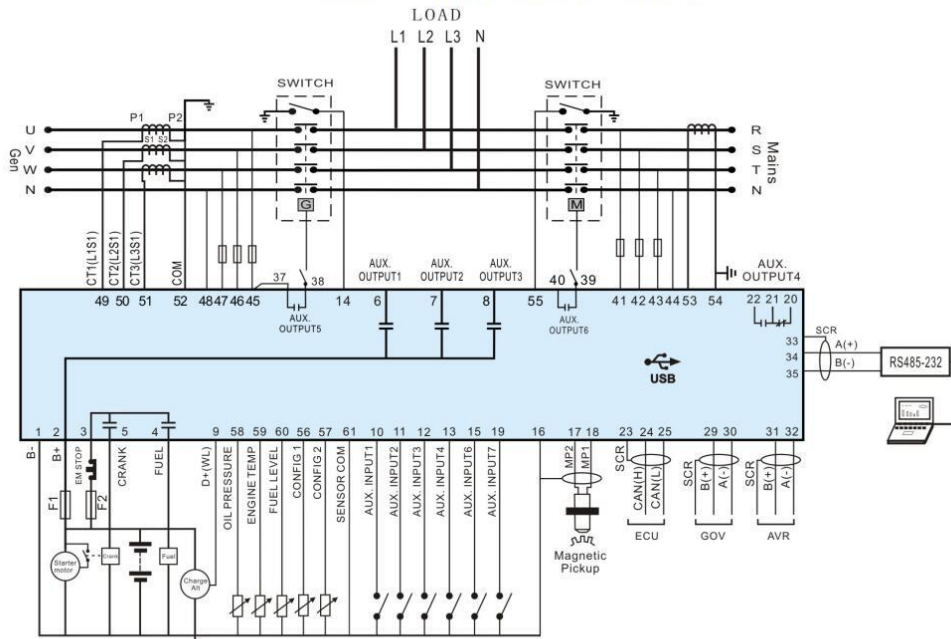

Note: Fuse F1: min. 2A; max. 20A. Fuse F2: max. 32A. Users should select suitable fuse depend on practical application.